

# Linear Actuators

## ML7420/ML7425

Linear Actuator, 0(2) ...10 V Signal, 600N

### Application

The ML7420/ML7425 actuators are designed for modulating control with controllers providing an analogue output of 0...10 V DC or 2...10 V DC. They operate Resideo's standard valves in heating, district heating, ventilation and air conditioning (HVAC) applications. Spring-return models provide a safety position at power failure.

### Approvals

- CE

### Special Features

- Easy and quick installation
- No separate linkage required
- No adjustments
- Low power consumption
- Force-limiting end switches
- Spring-return models
- Manual operator for ML7420 variants
- Position feedback signal
- 0...10 V DC or 2...10 V DC signal input selectable
- Direct / reverse action selectable
- Stroke position on signal failure selectable
- Corrosion-resistant design
- Maintenance-free
- Actuator-valve combinations approved according to DIN 14597 available



ML7420

ML7425



### Technical Data

Temperature	
Operating temperature:	-10 ... +50 °C at 5...95 % rh
Max. medium temperature for Resideo linear valves*:	150 °C
Max. medium temperature for Resideo Safety linear SV-valves:	130 °C
Weight	
Non-spring return type:	1.3 kg
Spring return type:	2.4 kg
Specifications	
Protection standard:	IP54 per EN60529
Protection class:	Class II per EN60730-1
Flame retardant housing:	UL 94-V0 (with metal cable gland – not supplied)
Operating mode:	Type 2B as per EN 60730-1
Wiring terminals:	1.5 mm <sup>2</sup>
Stroke:	20 mm
Closing force:	≥ 600 N
Signals	
Input voltage:	y = 0...10 V DC or 2...10 V DC R <sub>i</sub> = 100kΩ
Signal source:	1 kΩ max.
Position feedback signal:	x = 2...10 V DC
Load:	1 mA max.

\* When equipped with the High-Temp. Kit (see section Accessories), all actuators are suitable for medium valve temperatures of up to 220 °C.

## Construction

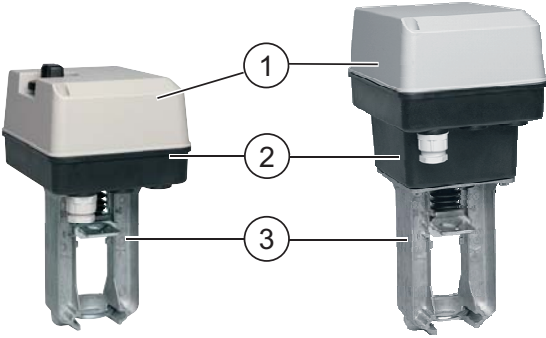
Overview	Components	Materials	
 <p>ML7420                      ML7425</p>	1	Cover	ABS-FR
	2	Base	glass fiber reinforced plastic
	3	Yoke	aluminum diecast

## Transportation and Storage

Keep parts in their original packaging and unpack them shortly before use.

The following parameters apply during transportation and storage:

Parameter	Value
Environment:	clean, dry and dust free
Min. ambient temperature:	-40 °C
Max. ambient temperature:	70 °C
Min. ambient relative humidity:	5 % *
Max. ambient relative humidity:	95 % *

\*non condensing

## Method of Operation

The drive of a synchronous motor is converted into linear motion of the actuator stem by using a spur gear transmission. The actuator stem is connected with the valve stem by a button keyed retainer connection.

An integrated spring package limits the stem force to a factory-adjusted value in either direction.

Installed micro switches switch off the actuator precisely when the specified stem force is reached.

### Manual Operation

Actuators without spring return (ML7420...) are equipped with a manual operator used in case of power failure. Manual operation is possible only after the power supply has been switched off or disconnected.

To operate, push the manual operator knob down and turn clockwise to move the stem downward and counter-clockwise to move the stem upward. If the actuator returns to automatic control, the manual operator knob unlocks automatically.

In the case of actuators with spring return, the manual operator is located under the cover.

### Spring Return

The ML7425 spring return actuators provide a defined safety position of the valve in case of power failure.

The spring return actuators are shipped from the factory with a shipment stop (to lock the knob) in order to allow connection of the stem button retainer to the valve stem without power supply.

### Override option

All actuators have an integrated override function.

When the override signal is applied, the actuator drives to the fully-open or fully-closed position, regardless of the controller signal.

## Installation Guidelines

### Electrical Installation

The actuators are delivered with a pre-installed cable gland M20x1.5 and two additional knock-outs for M16x1.5 and M20x1.5.

Max. cable length/diameter for field mounting:

- 200 m / 1.5 mm<sup>2</sup> (ML7420A6009) or
- 100 m / 1.5 mm<sup>2</sup> (ML7420A6017) or
- 50 m / 1.5 mm<sup>2</sup> (ML7425xxxx).

Note: To avoid malfunction, it is necessary to connect 24 V AC power and ground.

### Wiring

#### 0/2...10 V

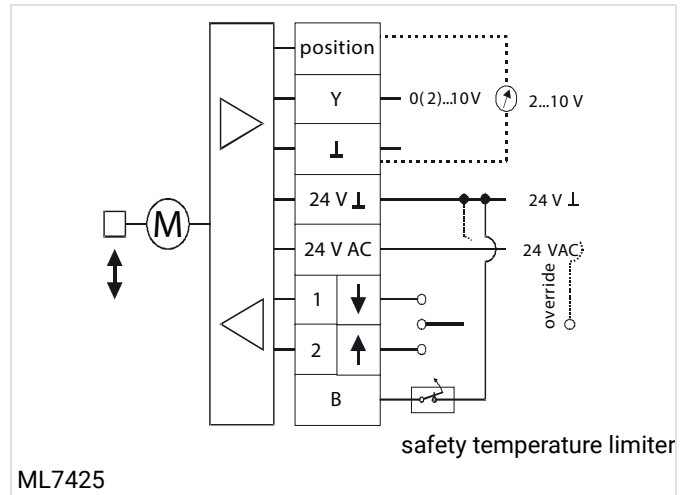
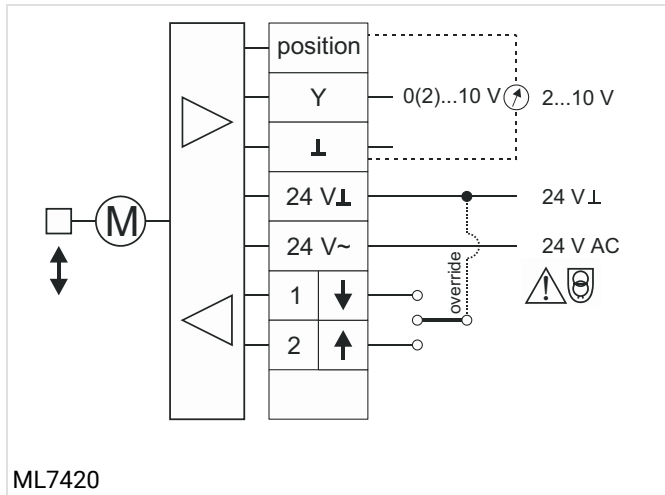

### Auxiliary switches

The actuators can be equipped on site with an auxiliary switch consisting of two switches. Their switching points are adjustable over the full length of the actuator stroke. The switches can be used to switch pumps or provide remote indication of any stroke position. A cable gland M20x1.5 is delivered with the unit.

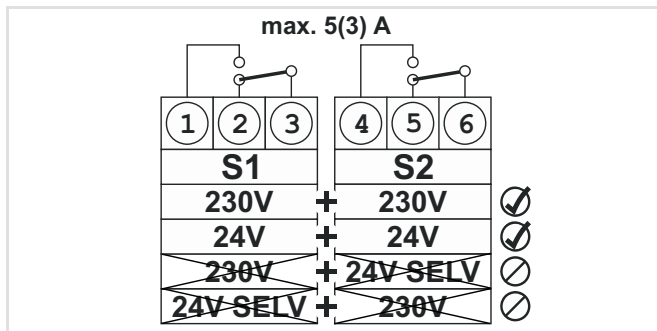

#### Action

The direction of action can be reversed by pressing the left-hand push button (W3) located on the printed circuit board, if the corresponding LED is lit, this indicates that the actuator stem will retract at a control signal of 0(2) V DC (factory setting); if it is dark, the actuator stem will extend at a control signal of 0(2) V DC.

#### Input Signal Range

The range of the analogue input signal Y can be changed by pressing the right-hand push button (W2) located on the printed circuit board. If the corresponding LED is lit, this indicates that the actuator is set for 0...10 V operation (factory setting); if it is dark, the actuator is set for 2...10 V operation.

### Input Signal Failure

Using the potentiometer (W1) located on the printed circuit board, the actuator can be adjusted such that in case the signal input fails (due, e.g., to a broken wire) or exceeds 12.5 V, the actuator will run to any pre-configured position between 0 % and 100 %. The factory setting is with the actuator stem in the central position (50 %).

Note: The two push buttons (W3 and W2) and the potentiometer (W1) are accessible after the cover has been removed and are located at the rear side of the protection sheet of the printed circuit board.

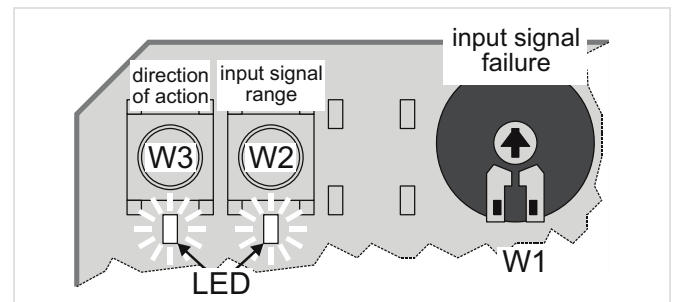

### Output Signal "POSITION"

An analogue output signal 2...10 V DC "POSITION" is available which represents the actual actuator position. It can be used for remote indication.

When the actuator stem is extended, the output signal is 10 V DC.

## Technical Characteristics

### Operation mode

	ML7420A6009	ML7420A6017	ML7425A6008	ML7425A6024	ML7425B6007
Voltage	24 V AC $\pm$ 15 %, 50/60 Hz				
Signal input 10 V DC *	Stem extended 2-way valve: "closed" 3-way valve port A-AB: "open"				
Signal input 0(2) V DC *	Stem retracted 2-way valve: "open" 3-way valve port A-AB: "closed"				

\* Factory setting; can be reversed by pressing the push button (W3) located on the PCB

### Safety Valve/Actuator combination with CE approval

Valve	Dimensions	Actuator
<b>CE0035 certified up to 130 °C</b>		
DF-B-NI-SV (PN16)	DN15 - DN80	ML7425A6008
DF-C-SV (PN25)		
DF-B-CI-SV (PN16)	DN15 - DN50	
DF-D-SV (PN40)		

### Close off pressure ratings in kPa

Valves	Valve size							
	DN15	DN20	DN25	DN32	DN40	DN50	DN65	DN80
DE/DI	1600	1600	1000	700	460	260	-	-
DF-B-CI	1600/1000	1000	1000	600	350	200	120	50
DF-B-NI	1600	1600	1600	1600	1600	1600	1600	1600
DF-C	2500	2500	2500	2500	2500	2500	2500	2500
DF-D	1600/1000	1000	1000	600	350	200	120	-
XE/XI	1600	1600	1000	700	460	260	-	-
XF-A	600	600	600	600	480	260	160	100
XF-B	1000	1000	1000	790	480	260	160	100
XF-D	1000	1000	1000	600	350	200	120	50

For details on the valves, see following data sheets:

DE/DI	EN0H-1773GE23	XE/XI	EN0H-1771GE23
DF-B-CI	EN0H-1769GE23	XF-A	EN0H-1778GE23
DF-B-NI	EN0H-1776GE23	XF-B	EN0H-1780GE23
DF-C	EN0H-1783GE23	XF-D	EN0H-1777GE23
DF-D	EN0H-1775GE23		

## Dimensions

### Overview

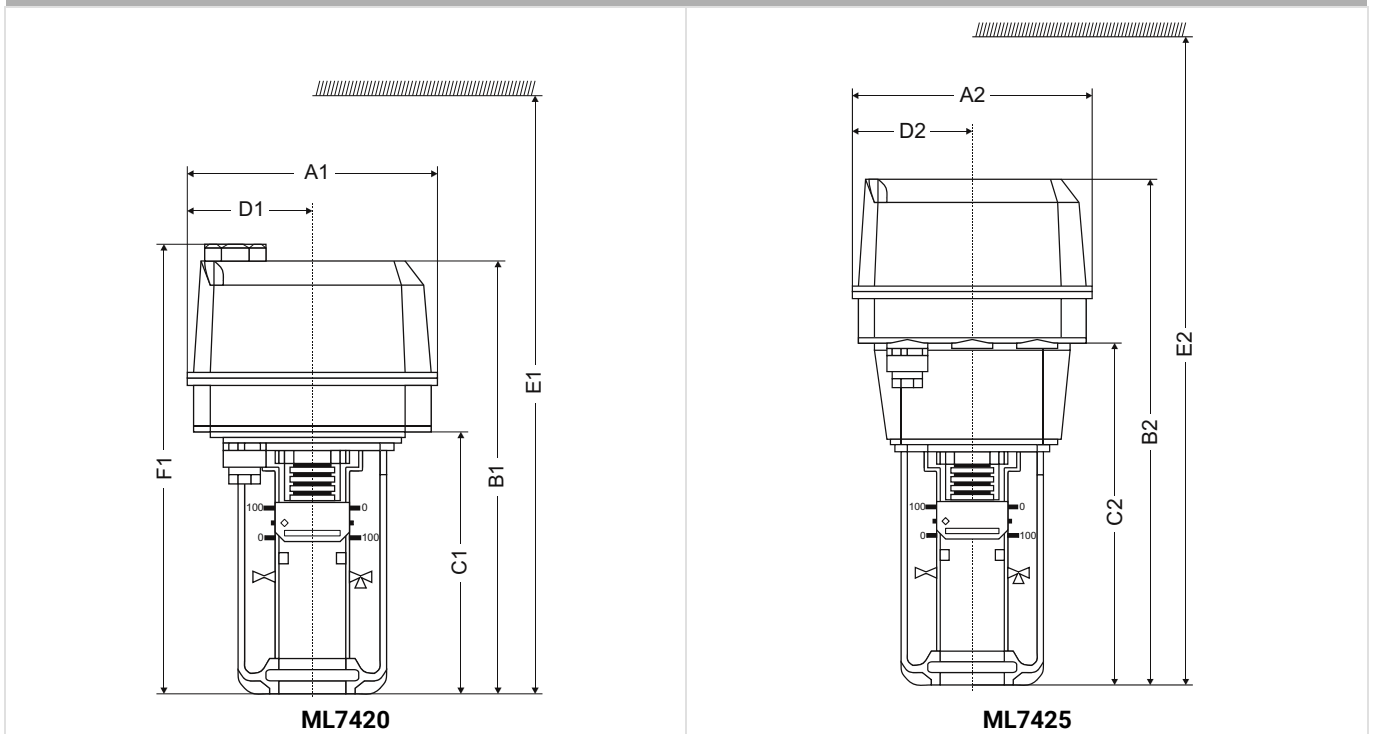

A1	B1	C1	D1	E1	F1	A2	B2	C2	D2	E2
135x161	233	141	67.4	322 *	242	135 x 161	284	192	67.4	364 **

Note: All dimensions in mm unless stated otherwise.

\* with High-Temperature Kit 402 mm

\*\* with High-Temperature Kit 444 mm



## Ordering Information

The following tables contain all the information you need to make an order of an item of your choice. When ordering, please always state the type, the ordering or the part number.

### Options

Supply voltage	Power consumption	Run time at 50 Hz	Spring return direction (at power failure)	Spring return time	Item No.
24 V AC	5 VA	1 min	-	-	ML7420A6009
	7 VA	0.5 min	-	-	ML7420A6017
	12 VA	1.8 min	actuator stem extends	≈ 12 s	ML7425A6008
	12 VA	1.8 min	actuator stem retracts	≈ 12 s	ML7425B6007

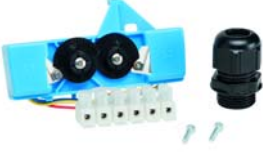
### Accessories

	Description	Dimension	Item No.
	<b>Auxiliary switches adjustable over the full length of the actuator stroke</b>		
	Auxiliary switch with 2 change-over switches, 230 V, 10 A, adjustable as desired via the stroke		43191680-005
	<b>High-Temperature Kit</b>		
	Note: For applications >150 °C and < 220 °C medium temperature		
	DE/DI	DN15 - DN50	43196000-001
	XE/XI	DN15 - DN50	
	DF-B-CI/XF-B	DN15 - DN32	43196000-002
	DF-B-CI/XF-B	DN40 - DN80	
	DF-D	DN15 - DN65	
DF-B-NI/DF-C/XF-D	DN15 - DN80		

# resideo

Ademco 1 GmbH, Hardhofweg 40,  
74821 MOSBACH, GERMANY  
Phone: +49 6261 810

Manufactured for and on behalf of  
Pittway Sàrl, Z.A., La Pièce 6,  
1180 Rolle, Switzerland

Subject to change. EN0H-1786GE23 R1123  
© 2023 Resideo Technologies, Inc.  
All rights reserved.

**For more information**  
resideo.com

This document contains proprietary information of Pittway Sàrl and its affiliated companies and is protected by copyright and other international laws. Reproduction or improper use without specific written authorization of Pittway Sàrl is strictly forbidden.